

# REVISIONS

SYM	DESCRIPTION	DATE	APPROVAL
-----	-------------	------	----------

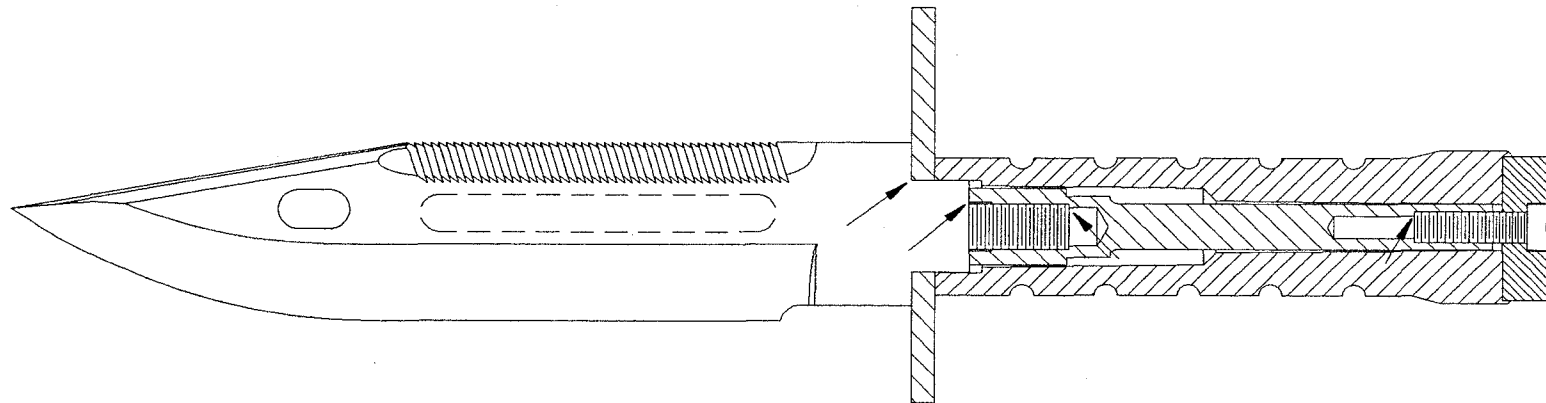

↗ SHARP CORNERS AND  
THREADS AT ALL JOINTS

CONFIDENTIAL AND PROPRIETARY INFORMATION  
© 1992, Buck Knives, Inc. All Rights Reserved.

THIS DOCUMENT CONTAINS CONFIDENTIAL AND PROPRIETARY INFORMATION OF BUCK KNIVES, INC. WHICH IS PROTECTED BY TRADE SECRET AND OTHER STATE AND FEDERAL LAWS. RECEIPT OR POSSESSION OF THIS DOCUMENT DOES NOT CONVEY ANY RIGHT TO REPRODUCE IT, DISCLOSE ITS CONTENTS TO ANY THIRD PARTY, OR USE ANYTHING CONTAINED HEREIN FOR THE BENEFIT OF ANY THIRD PARTY (WHETHER AS THE BASIS FOR MANUFACTURING OF OTHERWISE), REPRODUCTION, DISCLOSURE OR USE OF THE INFORMATION CONTAINED HEREIN WITHOUT THE SPECIFIC WRITTEN AUTHORIZATION OF BUCK KNIVES, INC. IS UNLAWFUL.

DRAWN BY: TAG		APPROVED BY: RJM		<b>BUCK KNIVES, INC.</b> 1900 WELD BOULEVARD EL CAJON, CA. 92020 (619) 449-1100	
NOTE UNLESS SPECIFIED		TITLE: M-9 BAYONET HANDLE CUTAWAY		PART NO. FIG. 1	
DECIMALS: XXX ± .005 XX ± .010		MATERIAL:		SIZE A	
FRACTIONAL ± 1/32		ANGULAR ± 0 30'		DRAWING NUMBER: 0188-101 REV.	
DATE: 3/2/94		SCALE:		SHEET 1 OF 1	

NOTES: CURRENT M-9 BAYONET WITH HANDLE ATTACHMENT

# REVISIONS

SYM	DESCRIPTION	DATE	APPROVAL
-----	-------------	------	----------

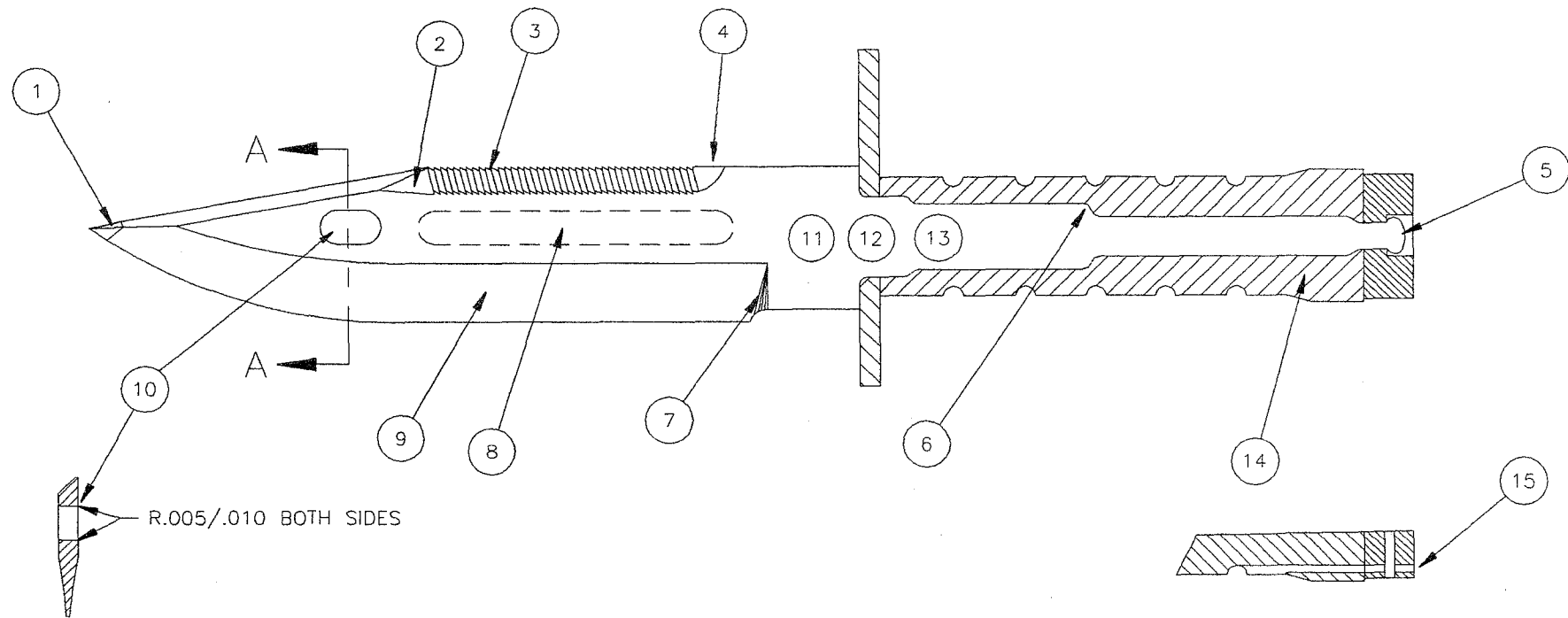

R.005/.010 BOTH SIDES

## SECTION A-A

ITEM	DESCRIPTION
1	SPEAR TIP (4) SIDED
2	BLEND STRAIGHT
3	R.030 ON ROOT OF SAW TEETH
4	REMOVE 1/2" FROM SAW TEETH
5	RADIAL RIVETING OF TANG END
6	R.060 TYP. INSIDE AND OUTSIDE
7	RADIUS AT FLAT GRIND
8	REMOVE BLOOD GROOVE FAR SIDE
9	FLAT GRIND
10	RADIUS OUTSIDE CORNERS
11	HEAT TREAT DOUBLE TEMPER RC 54/56
12	TANG ANNEAL FULL LENGTH
13	SURFACE FINISH BLACK OXIDE (TITANIUM NITRIDE / BLACK, OPTIONAL)
14	INJECTION MOLD HANDLE TO TANG
15	ROLL PIN DRIVE THRU (2) HOLES

NOTES: PROPOSED MODIFIED M-9 BAYONET

CONFIDENTIAL AND PROPRIETARY INFORMATION  
 © 1992, Buck Knives, Inc. All Rights Reserved.  
 THIS DOCUMENT CONTAINS CONFIDENTIAL AND PROPRIETARY INFORMATION OF BUCK KNIVES, INC. WHICH IS PROTECTED BY TRADE SECRET AND OTHER STATE AND FEDERAL LAWS. RECEIPT OR POSSESSION OF THIS DOCUMENT DOES NOT CONVEY ANY RIGHT TO REPRODUCE IT, DISCLOSE ITS CONTENTS TO ANY THIRD PARTY, OR USE ANYTHING CONTAINED HEREIN FOR THE BENEFIT OF ANY THIRD PARTY (WHETHER AS THE BASIS FOR MANUFACTURING OF OTHERWISE). REPRODUCTION, DISCLOSURE OR USE OF THE INFORMATION CONTAINED HEREIN WITHOUT THE SPECIFIC WRITTEN AUTHORIZATION OF BUCK KNIVES, INC. IS UNLAWFUL.

DRAWN BY: TAG	APPROVED BY: RJM	<b>BUCK KNIVES, INC.</b> 1900 WELD BOULEVARD EL CAJON, CA. 92020 (619) 449-1100	
NOTE UNLESS SPECIFIED	DECIMALS: XXX ±.005 XX ±.010	TITLE: M-9 BAYONET HANDLE CUTAWAY	PART NO. FIG.2
FRACTIONAL ± 1/32	MATERIAL: 425 MOD. MARTINSITIC STAINLESS STEEL	SIZE A	DRAWING NUMBER: 0188-102 REV.
ANGULAR ± 0 30'	DATE: 3/2/94	SCALE:	SHEET 1 OF 1

# REVISIONS

SYM	DESCRIPTION	DATE	APPROVAL
-----	-------------	------	----------

 SPECIAL NUT, DESIGNED TO USE  
 STANDARD LATCH PLATE.  
 NUT IS TIGHTENED WITH A  
 SPANNER WRENCH.

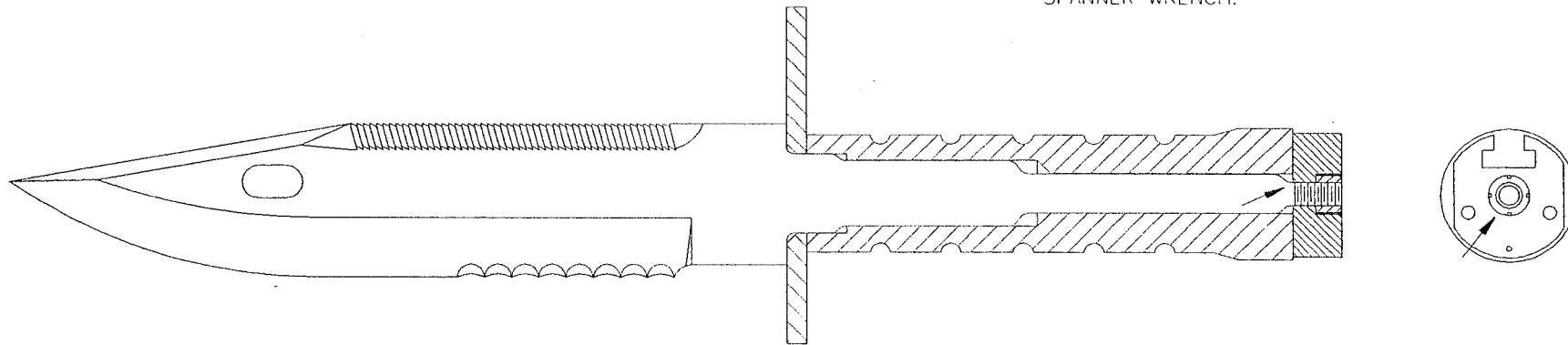

 THREADED TANG; SHARP EDGES  
 ON ROOT OF THREADS.

NOTES:

DRAWN BY:	APPROVED BY:	<b>BUCK KNIVES, INC.</b>	
		1900 WELD BOULEVARD EL CAJON, CA. 92020 (619) 449-1100	
NOTE UNLESS SPECIFIED		TITLE: M-9 BAYONET HANDLE CUTAWAY	PART NO.
DECIMALS: XXX ±.005 XX ±.010	MATERIAL:	SIZE <b>B</b>	DRAWING NUMBER: 0188-104
FRACTIONAL ± 1/32		DATE:	REV.
ANGULAR ± 0.30'		SCALE:	SHEET OF

# REVISIONS

SYM	DESCRIPTION	DATE	APPROVAL
-----	-------------	------	----------

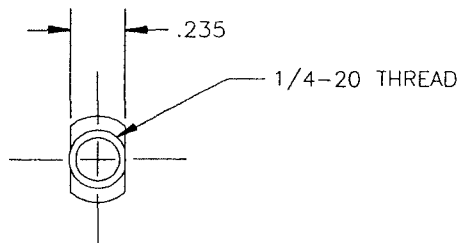
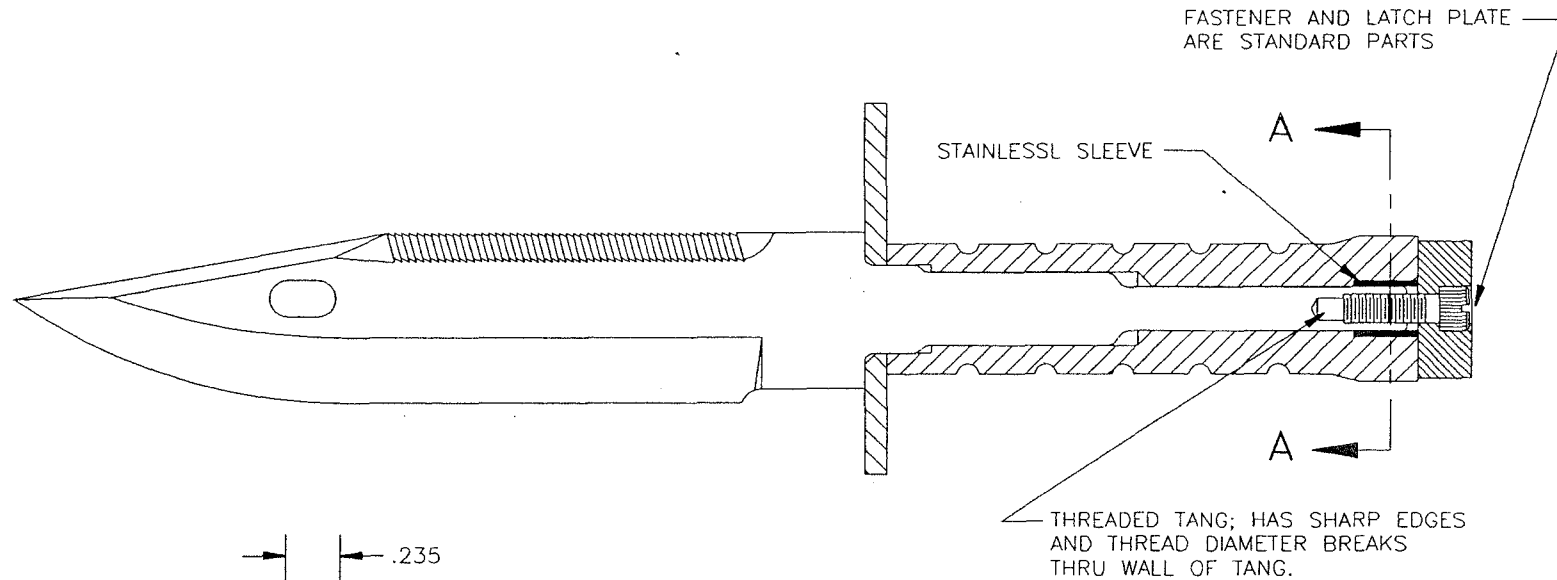

SECTION A-A  
SCALE 2:1

NOTES: ALTERNATIVE HANDLE ATTACHMENT

DRAWN BY:	APPROVED BY:	<b>BUCK KNIVES, INC.</b>	
		1900 WELD BOULEVARD EL CAJON, CA. 92020 (619) 449-1100	
NOTE UNLESS SPECIFIED		TITLE:	PART NO.
DECIMALS: XXX ±.005 XX ±.010	MATERIAL:	M-9 BAYONET HANDLE CUTAWAY	
FRACTIONAL ± 1/32		SIZE B	DRAWING NUMBER: 0188-105
ANGULAR ± 0 30'		DATE:	REV.
		SCALE:	SHEET OF

# REVISIONS

SYM	DESCRIPTION	DATE	APPROVAL
-----	-------------	------	----------

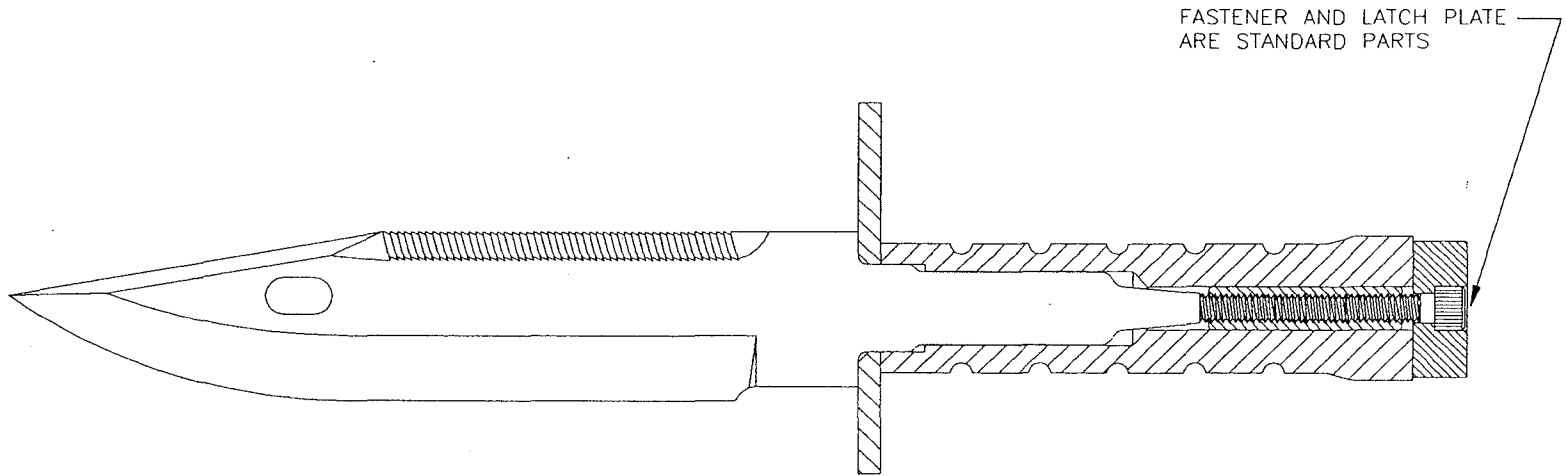

DRAWN BY:	APPROVED BY:	<b>BUCK KNIVES, INC.</b>	
		1900 WELD BOULEVARD EL CAJON, CA. 92020 (619) 449-1100	
NOTE UNLESS SPECIFIED		TITLE: M-9 BAYONET HANDLE CUTAWAY	PART NO.
DECIMALS: XXX ±.005 XX ±.010	MATERIAL:	SIZE B	DRAWING NUMBER: 0188-106
FRACTIONAL ± 1/32		DATE:	REV.
ANGULAR ± 0 30'		SCALE:	SHEET OF

NOTES: ALTERNATIVE HANDLE ATTACHMENT

